

- Roy CN, Enns CA. Iron homeostasis: new tales from the crypt. *Blood*. 2000;96:4020–4027.
- Park CH, Valore EV, Waring AJ, Ganz T. Heparin, a urinary antimicrobial peptide synthesized in the liver. *J Biol Chem*. 2001;276:7806–7810.
- Krause A, Neitz S, Magert H-J, Schulz A, Forssmann WG, Schulz-Knappe P, et al. LEAP-1, a novel highly disulfide-bonded human peptide, exhibits antimicrobial activity. *FEBS Lett*. 2000;480:147–150.
- Pigeon C, Ilyin G, Courselaud B, Leroyer P, Turlin B, Brissot P, et al. A new mouse liver-specific gene, encoding a protein homologous to human antimicrobial peptide hepcidin, is overexpressed during iron overload. *J Biol Chem*. 2001;276:7811–7819.
- Nicolas G, Bennoun M, Devaux I, Beaumont C, Grandchamp B, Kahn A, et al. Lack of hepcidin gene expression and severe tissue iron overload in upstream stimulatory factor 2 (USF2) knockout mice. *Proc Natl Acad Sci U S A*. 2001;98:8780–8785.
- Vallet VS, Henrion AA, Bucchini D, Cassado M, Raymondjean M, Kahn A, et al. Glucose-dependent liver gene expression in Upstream Stimulatory Factor 2 mice. *J Biol Chem*. 1997;272:21994–1999.
- Sirito M, Lin Q, Deng JM, Behringer RR, Sawadogo M. Overlapping roles and asymmetrical cross-regulation of the USF proteins in mice. *Proc Natl Acad Sci U S A*. 1998;95:3758–3763.
- Feder JN, Gnirke A, Thomas W, Tsuchihashi Z, Ruddy DA, Basava A, et al. A novel MHC class I-like gene is mutated in patients with hereditary hemochromatosis. *Nat Genet*. 1996;13:399–408.
- Levy JE, Montross LK, Cohen DE, Fleming MD, Andrews NC. The C282Y mutation causing hemochromatosis does not produce a null allele. *Blood*. 1999;94:9–11.
- Zhou XY, Tomatsu S, Fleming RE, Parkkila S, Waheed A, Jiang J, et al. HFE gene knockout produces mouse model of hemochromatosis. *Proc Natl Acad Sci U S A*. 1998;95:2492–2497.
- Camaschella C, Roetto A, Cali A, DeGobbi M, Garozzo G, Carella M, et al. The gene TFR2 is mutated in a new type of haemochromatosis mapping to 7q22. *Nat Genet*. 2000;25:14–15.
- Nicolas G, Bennoun M, Porteu A, Mativet S, Beaumont C, Grandchamp B, et al. Severe iron deficiency anemia in transgenic mice expressing liver hepcidin. *Proc Natl Acad Sci U S A*. 2002;99:4596–4601.
- Parkkila S, Waheed A, Britton RS, Bacon BR, Zhao XY, Tomatsu S, et al. Association of the transferrin receptor in human placenta with HFE, the protein defective in hereditary hemochromatosis. *Proc Natl Acad Sci U S A*. 1997;94:13198–13202.
- Georgieff MK, Wobken JK, Welle J, Burdo JR, Connor JR. Identification and localization of divalent metal transporter-1 (DMT-1) in term human placenta. *Placenta*. 2000;21:799–804.
- Fleming MD, Trenor CC, Su MA, Foerzler D, Beier DR, Dietrich WF, et al. Microcytic anemia mice have a mutation in Nramp2, a candidate iron transporter gene. *Nat Genet*. 1997;16:383–386.
- Donovan A, Brownlie A, Zhou Y, Shepard J, Pratt SJ, Moynihan J, et al. Positional cloning of zebrafish ferroportin 1 identifies a conserved vertebrate iron exporter. *Nature*. 2000;403:776–781.
- McKie AT, Marciani P, Rolfs A, Brennan K, Wehr K, Barrow D, et al. A novel duodenal iron-regulated transporter, IREG1, implicated in the basolateral transfer of iron to the circulation. *Mol Cell*. 2000;5:299–309.
- Fleming R, Sly WS. Heparin: a putative iron-regulatory hormone relevant to hereditary hemochromatosis and the anemia of chronic disease. *Proc Natl Acad Sci U S A*. 2001;98:8160–8162.

The Regulation of the Thyroid-stimulating Hormone of the Anterior Pituitary Gland by Thyroid Hormone and by 9-Cis-Retinoic Acid

Thyroid-stimulating hormone, TSH, of the anterior pituitary gland is regulated by the binding of the thyroid hormone-activated thyroid receptor to the TSH gene at the same time as the binding of the 9-cis-retinoic acid-activated retinoid X receptor to the same gene. Both interactions, separately or simultaneously, can suppress and thus regulate the expression of the TSH gene.

Key Words: anterior pituitary gland, thyroid hormone, thyroid-stimulating hormone, vitamin A, thyroid receptor, retinoid X receptor, 9-cis-retinoic acid

© 2002 International Life Sciences Institute

This review was prepared by George Wolf, D.Phil., Department of Nutritional Sciences and Toxicology, University of California, Berkeley, CA 94720-3104, USA. Please send all reprint requests to the *Nutrition Reviews* Editorial Office, 711 Washington Street, Boston, MA 02111, USA.

An association between vitamin A and thyroid hormones has been known since the 1940s.¹ Investigators observed an increase in thyroid hormones in the serum of vitamin A-depleted rats² and, conversely, a significant decrease in the serum thyroid hormones triiodothyronine (T₃) and tetraiodothyronine (T₄) in rats fed excess vitamin A.³ The anterior pituitary gland was implicated because vitamin A-deficient rats also showed increased serum levels of the anterior pituitary thyroid-stimulating hormone (TSH).⁴ Sherman et al.⁵ recently found that the

association between vitamin A and the pituitary-thyroid axis also applied to humans. A group of 27 patients with cutaneous T-cell lymphoma was treated with a synthetic retinoid (bexarotene) that specifically binds to the retinoid X receptor (RXR). An unintended side effect of this treatment was a twofold decrease in the patients' serum free thyroxine level and a 40-fold decrease in their serum TSH level, with symptoms of hypothyroidism appearing in 19 of the patients.

The anterior pituitary hormone TSH consists of two noncovalently bound glycoprotein subunits—TSH α , common to all anterior pituitary hormones, and TSH β , unique to the thyrotropic cells of the anterior pituitary. Secretion of TSH into the circulation stimulates the thyroid gland to secrete T₃ and T₄. Conversely, T₃ and T₄ regulate the output of TSH by feedback inhibition of the transcription of the *TSH α* and *TSH β* genes.⁶ The level of thyroxine in the serum is therefore kept constant; increases in T₃ and T₄ inhibit TSH production, whereas decreases relieve this inhibition, allowing TSH to stimulate the thyroid.

The inhibition of TSH formation occurs through action of the thyroid receptor (TR), a nuclear protein belonging to the family of nuclear receptors that include the retinoid, vitamin D, and peroxisome proliferator-activated receptor. T₃, when bound to the TR monomer, which occupies a TR element half-site on the promoter DNA of the *TSH β* gene, suppresses transcription of the gene. Recent work suggested that TR acted not as a monomer, but as a heterodimer, binding to DNA together with liganded RXR.⁷

RXR occurs in the form of three isomers: RXR α , RXR β , and RXR γ . Whereas the α and β isoforms are widely distributed throughout the mammalian organism, the occurrence of RXR γ is restricted to skeletal muscle and brain; it is particularly abundant in the thyrotrope cells of the anterior pituitary gland.⁸ The increase in serum thyroid hormones and serum TSH observed when rats were made vitamin A-deficient³ led to the hypothesis that 9-*cis*-retinoic acid (9-*cis*-RA), the known ligand of RXR, is involved in the suppression of TSH expression. Thus, Breen et al.⁹ showed that vitamin A-deficient rats expressed increased levels of the TSH β subunit of TSH. The case was clinched by Haugen et al.⁸ in the following way.

RXR γ exists in two isoforms—RXR γ 1 and RXR γ 2—that are generated by alternate splicing of the RXR γ mRNA.¹⁰ Haugen et al.⁸ used TtT-97 cells in culture, derived from an anterior pituitary thyrotrope tumor. They determined by Northern blot analysis that RXR γ 1 mRNA was expressed exclusively in the thyrotrope TtT-97 cells, whereas RXR γ 2 appeared in other anterior pituitary cells, such as somatomammotropes (GH3 cells), but was lacking in the TtT-97 cells.

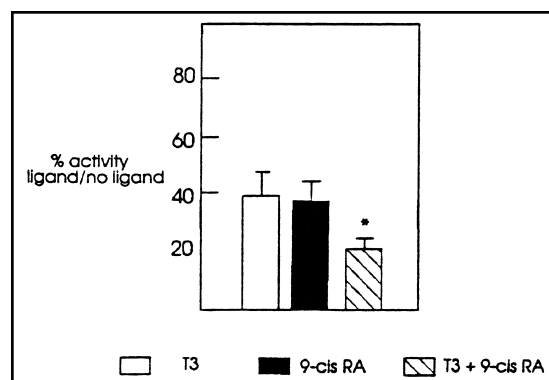

Figure 1. Murine TSH β promoter activity in TtT-97 cells in the presence of T₃ or 9-*cis*-RA. Mouse TSH β (–390 to +40) promoter-luciferase reporter DNA was transfected into TtT-97 cells. These were incubated in the absence or presence of T₃, 9-*cis*-RA, or both. Results are expressed as percent promoter activity in the presence of ligand versus no ligand. Asterisk denoted a significant difference ($P < 0.05$) between the T₃/9-*cis*-RA group and the other two groups (from reference 8, with permission).

By transfecting a TSH β promoter DNA attached to a luciferase reporter DNA into TtT-97 cells, the authors⁸ found that the reporter indicated a 60% suppression of its activity in the presence of the thyroid hormone T₃, a 60% suppression in the presence of 9-*cis*-RA, but an 80% suppression by a combination of T₃ and 9-*cis*-RA (Figure 1). This important experiment showed that T₃ became attached to TR at the same time as 9-*cis*-RA became attached to RXR γ 1; both receptors were residing on the TSH β promoter. The result was the strong suppression of TSH β expression in the presence of T₃ and 9-*cis*-RA (Figure 2). For a control experiment, the authors⁸ used pituitary somatomammotrope cells (GH3 cells) that respond to T₃, but lack RXR γ 1; transfecting the TSH β promoter-luciferase reporter DNA into these cells showed a response of the reporter to T₃ (60% suppression), but not to 9-*cis*-RA.

Deletion mapping placed the 9-*cis*-RA-mediated suppression on the TSH β promoter between –200 and –149 bp, similar to the findings of Breen et al.,⁶ who also determined that the T₃-responsive elements reside between –15 and +9 bp.

A more recent report by Brown et al.¹⁰ described the effect of disruption of the RXR γ gene on the response of the pituitary-thyroid axis. The RXR γ knockout mice were produced according to Krezel et al.¹¹ in the following way. An embryonic stem cell-derived genomic library was screened with a mouse RXR γ full-length DNA probe. A 2.5-kb fragment harboring the RXR γ DNA binding domain in the RXR γ gene was replaced by a PGK-NED-poly(A)+ cassette. The resulting DNA was electroporated into embryonic stem cells. Clones were prepared and injected into mouse blastocysts. From the litters obtained, homozygous mice were produced by

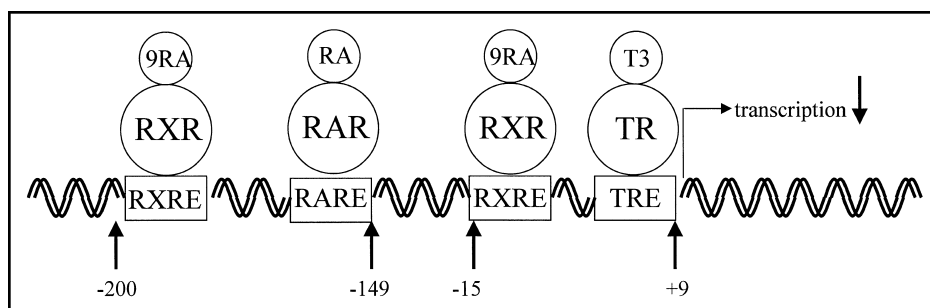

Figure 2. Hypothetical and simplified diagram of the promoter region of the *TSHβ* gene. 9RA = 9-*cis*-RA, RXR = RXR γ 1, RXRE = retinoid X-receptor element, RA = retinoic acid, RAR = retinoic acid receptor, RARE = retinoic acid receptor element, T3 = triiodothyronine, TR = thyroid receptor, TRE = thyroid receptor element. Numbers denote nucleotide base pairs from transcription start site. Downward arrow denotes suppression of transcription.

heterozygous matings. These mice were phenotypically normal in their viability and fertility, but failed to express the *RXRγ* gene in their pituitary glands.¹² Using these *RXRγ* knockout mice, Brown et al.¹⁰ showed complete absence of both *RXRγ*1 and *RXRγ*2 mRNA, normal levels of *RXRα* and *RXRβ* mRNA, and slightly higher *TSHβ* mRNA levels. Serum TSH concentration was also somewhat higher in the *RXRγ*^{-/-} mice. Wild-type and *RXRγ*^{-/-} mice were made hyperthyroidic by giving them increasing amounts of T₃ in their drinking water. The wild-type mice, by the normal process of feedback inhibition of TSH secretion in response to the increased serum T₃, showed severe suppression of their serum TSH level; serum TSH at the higher T₃ intakes completely disappeared (Figure 3). In the *RXRγ*^{-/-} mice, administration of T₃ also resulted in its suppression, but to a much lesser degree than in the mutants; it was never completely suppressed, even at high T₃ intakes (Figure 3). This result indicated that in the wild-type mice both the TR and the *RXRγ*, acting on the TSH promoter, responded with suppression of TSH. In the *RXRγ*^{-/-}

mice, the TR on the TSH promoter, which was intact, responded to the increased T₃. However, the lack of *RXRγ* attenuated this response, because there was no receptor to which 9-*cis*-RA could bind.

In an inverse experiment, hypothyroid mice were prepared by ablation of the thyroid gland through injection of radioactive iodine. Four months of this treatment resulted in a radical (35-fold) decrease in serum T₄ in the wild-type mice, and a much lesser decrease in the mutant mice (sixfold). As in the hyperthyroid experiment, the serum TSH levels of both the wild-type and the *RXRγ*^{-/-} mice responded; the serum level of the wild-type TSH rose 40-fold from the level of untreated controls. The TSH of the mutants showed higher levels than the normothyroid controls, despite the mutants' higher serum T₄ compared with wild-type controls. One would have expected the higher serum T₄ to suppress the TSH level, but in absence of *RXRγ* the response of the pituitary hormone was diminished. Again, this experiment indicated attenuation of the TSH response in absence of the *RXRγ* receptor, which prevents an input of the retinoid through its receptor.

The authors,¹⁰ by means of whole-animal indirect calorimetric measurements, determined that the *RXRγ*^{-/-} mice had a metabolic rate 37% higher than their wild-type littermates; this may be the case because the *RXRγ*^{-/-} mice had increased levels of serum T₄.

In conclusion, the regulation of the anterior pituitary hormone TSH depends on two factors: the binding of the TR, which is activated by T₃ and T₄, to the *TSHβ* gene, and the binding of the *RXRγ*1, which is activated by 9-*cis*-RA, to the same gene. Each interaction alone and both interactions simultaneously inhibit expression of *TSHβ* mRNA and TSH hormone production. In this way, there occurs not only the feedback inhibition of serum TSH by serum T₃ and serum T₄, but also inhibition by vitamin A. The physiologic significance of this unique inhibitory action by vitamin A on a hormone remains unclear.

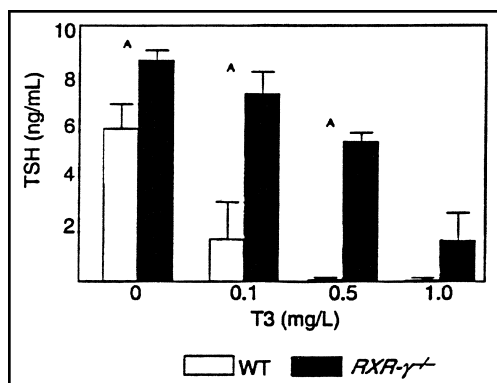

Figure 3. T₃ suppression test in littermate mice. Serum from wild-type (open bars) and *RXRγ*^{-/-} (filled bars) mice was collected after 10 days of treatment with different levels of T₃ in the drinking water. TSH levels at each treatment dose are shown. "A" denotes a significant difference, *P* < 0.05 (from reference 10, with permission).

1. Simkins S. Use of massive doses of vitamin A in the treatment of hyperthyroidism. *J Clin Endocrinol Metab.* 1947;7:574–585.
2. Garcin H, Higuieret P. Thyroid hormones in vitamin A-deficient rats: effects of retinoic acid supplementation. *Ann Nutr Metab.* 1983;27:495–500.
3. Garcin H, Higuieret P, Amoikon K. Effects of a large dose of retinol or retinoic acid on the thyroid hormones in the rat. *Ann Nutr Metab.* 1984;28:92–100.
4. Morley JE, Damassa DA, Gordon J, Pekary AE, Hershman JM. Thyroid function and vitamin A deficiency. *Life Sci.* 1978;22:1901–1906.
5. Sherman SI, Gopal J, Haugen BR, et al. Central hypothyroidism associated with retinoid X receptor-selective ligands. *N Engl J Med.* 1999;340:1075–1079.
6. Breen JJ, Hickok NJ, Guff JA. The rat TSH β gene contains distinct response elements for regulation by retinoids and thyroid hormone. *Mol Cell Endocrinol.* 1997;131:137–146.
7. Li D, Li T, Wang F, Tian H, Samuels HH. Functional evidence for retinoid X receptor (RXR) as a nonsilent partner in the thyroid hormone receptor/RXR heterodimer. *Mol Cell Biol.* 2002;22:5782–5792.
8. Haugen BR, Brown NS, Wood WM, Gordon DF, Ridgway EC. The thyrotrope-restricted isoform of the retinoid-X receptor- γ 1 mediates 9-*cis*-retinoic acid suppression of thyrotropin- β promoter activity. *Mol Endocrinol.* 1997;11:481–489.
9. Breen JJ, Matsuura T, Ross AC, Gurr JA. Regulation of thyroid-stimulating hormone beta-subunit and growth hormone messenger ribonucleic acid levels in the rat: effect of vitamin A status. *Endocrinology.* 1995;136:543–549.
10. Brown NS, Smart A, Sharma V, et al. Thyroid hormone resistance and increased metabolic rate in the RXR- γ -deficient mouse. *J Clin Invest.* 2000;106:73–79.
11. Krezel W, Dupe V, Mark M, Dierich A, Kastner P, Chambon P. RXR γ null mice are apparently normal and compound RXR α ^{+/-}/RXR β ^{-/-}/RXR γ ^{-/-} mutant mice are viable. *Proc Natl Acad Sci U S A.* 1996;93:9010–9014.
12. Liu Q, Linney E. The mouse retinoid-X receptor-gamma gene: genomic organization and evidence for functional forms. *Mol Endocrinol.* 1993;7:651–658.

